

# OPERATIONAL MANUAL ( Superfeed Controllers)



**CONTROLLER SVF – 388**

# Content Page

Introduction .....	3
Precaution .....	4
General Usage .....	4
Preventing Electric Shock .....	4
General Handling.....	4
Specifications.....	5
Features .....	6
12V Sensor Terminal .....	8
Input/Output Terminal .....	9
Input (3 pin plug) .....	9
Output (Bowl).....	9
Preparations .....	10
Operation .....	11
1) Power Up.....	11
2) Frequency Setting .....	11
3) On/Off Output .....	12
4) Modifying Delay On Time .....	12

## **Introduction**

Thank you for your purchase purchasing Fujicon products.

For correct operation of the controller, read the operational manual carefully before use.

This is to ensure safety and optimal performance.

It would be highly recommended to keep the operation manual carefully after use.

## **Precaution**

Please refer to the disclaimer statement on the bottom of the page.

## **General Usage**

Part feeder is a heavy machine. As such, extra caution must be taken during the movement, setting up and installation of the part feeder.

Any mishandling may cause physical injuries.

The control system consists of different types of controllers and devices. Users should refer to the manual for instructions (if any) should there be a need for any adjustments or maintenance.

When in doubt, call for technical assistance.

## **Preventing Electric Shock**

Below are some pointers for any users unfamiliar with electrical wiring and set up.

- 1) Turn OFF primary power source, before any wiring and maintenance.
- 2) Connect the grounding wire (green/yellow) before setting up.
- 3) Never make a direct wire connection between input and output outlets.
- 4) Check to ensure wiring insulation in use is AC 115 V / AC 230V.
- 5) Single phase connections(Brown and blue wire for power, green/yellow for grounding)

## **General Handling**

- 6) Do not drop or hit the Controller with great impact.
- 7) Do not sprinkle or submerge the SVF 888 Controller in water.
- 8) After switching off the power, give the Controller some time to fully discharge the current.
- 9) Switch off the power before performing any maintenance work.
- 10) Switch off the power before removing the cover of the controller.
- 11) Lift the Controller by its body and not with its cable.

### **Disclaimer**

The Feeder manufacturer (Fujicon) is not responsible for any damages/faults to machine, human injury caused by the parts feeder after being modified or additionally processed by a third party other than the one recommended by the manufacturer after delivery.

Any specifications and content in this manual are subjected to change without prior notice. The manufacturer will not be responsible for any misrepresentations made by the manual should there be any changes in the contents in the manual. Users are advised to contact the manufacturer if they have any doubts.

## **Specifications**

Input Voltage Source	115 Vac	230 Vac
Control Sensor Input	12 V NPN	12 V PNP
Output Voltage	100 Vac	200 Vac
Max Current	5 Ampere	
Frequency Range	37.2 Hz	510.2 Hz
Soft-Start	0	255
On Delay	0	255
Off Delay	0	255

Operation Mode	Constant Voltage
The controller controls the output constant voltage at the tuned frequency	
Housing Color	Orange
Case Material	Metal

Ambient Temp	0- 40 Degree Celsius	
Moisture Level	10%	90%
(no condensation allowed)		
Location	Indoor without corrosive gas and dust or harmful circumstances	

Applicable Condition	Noise Resistance 1000V or more
----------------------	-----------------------------------

## **Features**

- 1) Variable Frequency Selection Range (37.2 Hz to 510.2 Hz)
  
- 2) Soft Start ( 0 to 255 sec)
  
- 3) Sensor attachable
  - On delay timing (0 to 255 sec)
  - Off delay timing (0 to 255 sec)
  
- 4) Adjustable Amplitude Control
  - Adjust (0-10) clockwise to increase amplitude.
  
- 5) 4 Buttons (SET, MODE, UP, DOWN)
  - To access controller system to control frequency and timing delays.

## **Others**

- 6) Internal Fan For Better Heat Dissipation
  
- 7) Functional In Both 100V and 230V Power Supply
  
- 8) External Run/Stop Operation Switch

## Connections

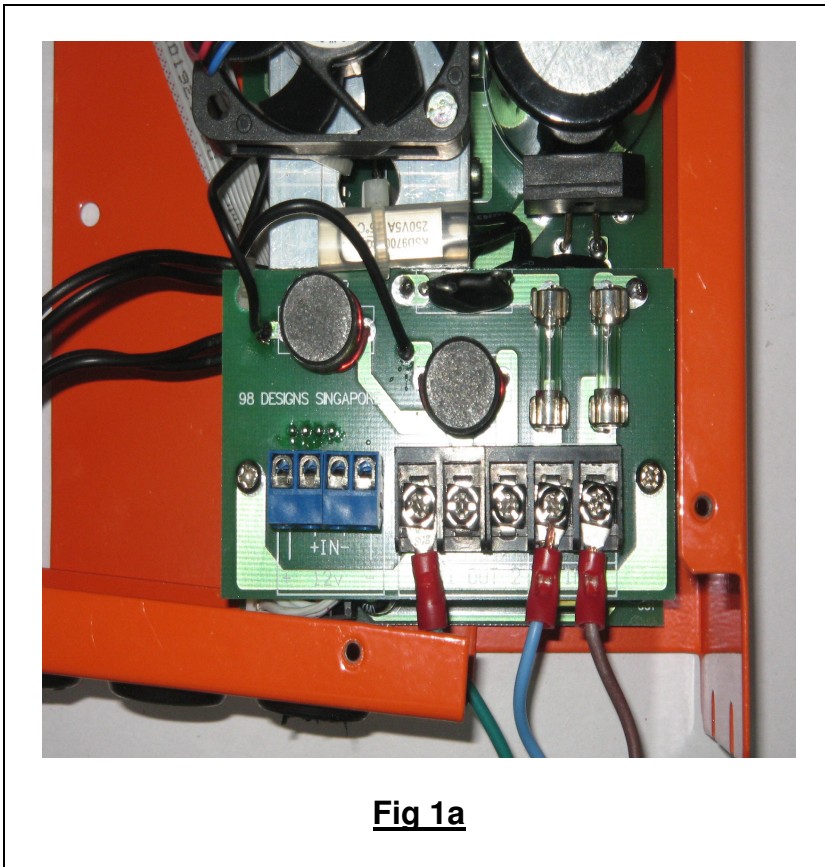

**Fig 1a**

**Figure 1a** shows an overview of the controller's internal circuitry. When you connect the wires (input and output), it should look like as shown. For example, brown wire to LIVE (input), blue wire to NEUTRAL (input), and green wire to EARTH

**Figure 1b** shows an exploded view. The left blue box shows the connection for the sensor. The right black box shows input/output of the wiring connection.

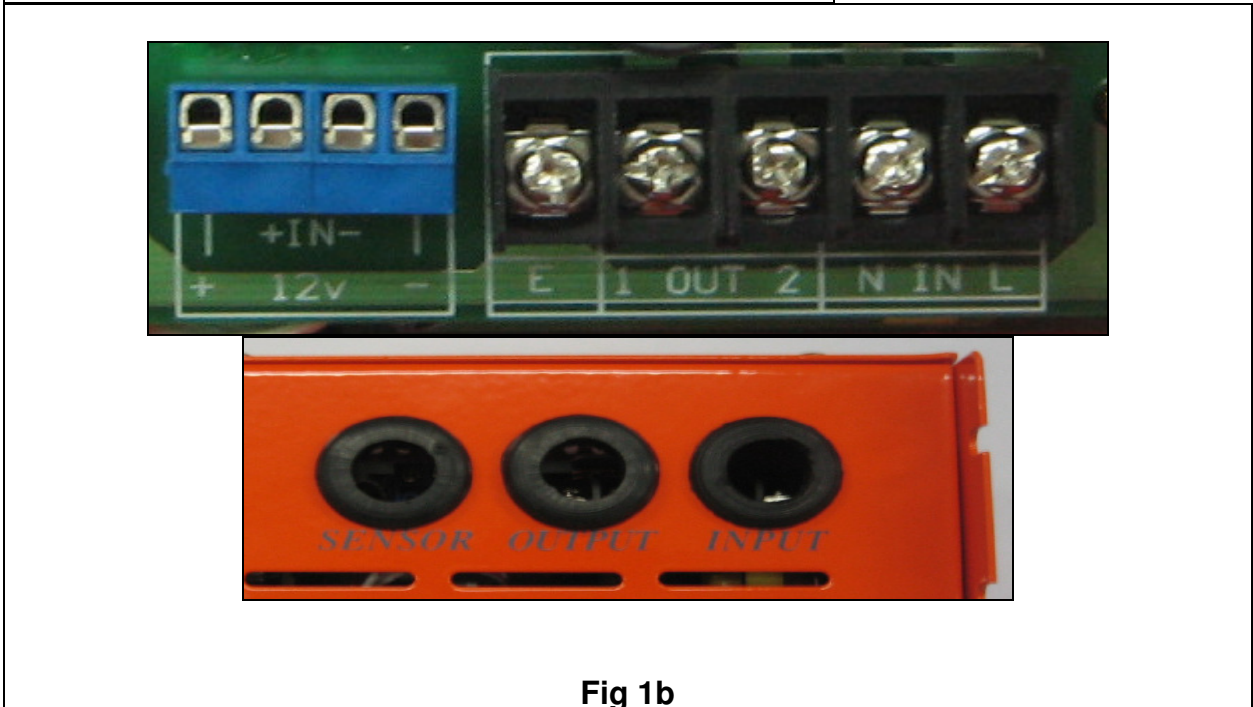

**Fig 1b**

## 12V Sensor Terminal

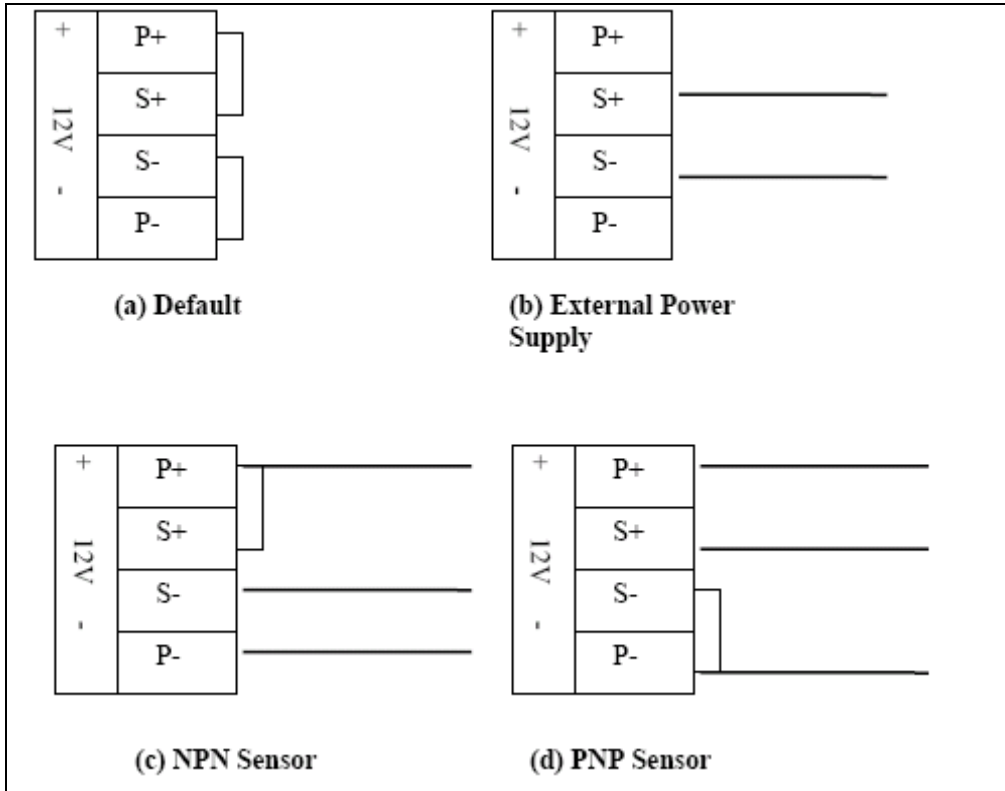

By default as shown in (a), both the positive and negative signals (S+, S-) of the 12V Sensor Terminal is connected to the positive and negative power supply (P+, P-).

For NPN Sensor, remove the connection of the P- to S- and connect the positive, negative and signal wires of the sensor to the terminal as shown in (c).

For the PNP Sensor, remove the connection of the P+ to S- and connect the positive, negative and signal wires of the sensor to the terminal as shown in (d).

## Input/Output Terminal

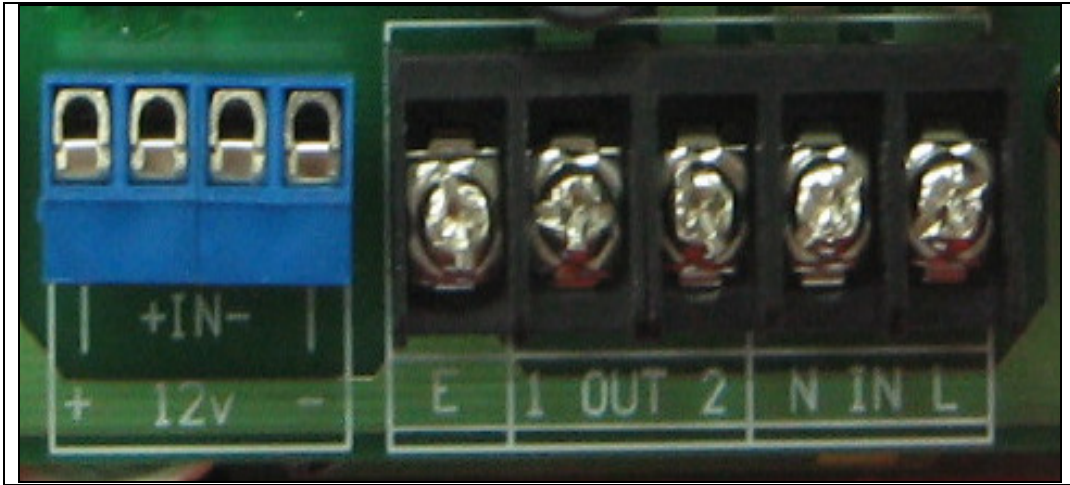

### **Input (3 pin plug)**

Connect to Earth, Neutral and Live. The usual chosen colors are Green/Yellow for Earth, Blue for Neutral and Brown for Live.

### **Output (Bowl)**

Connect to Earth, Output 1 and Output 2. The usual color for Earth is Green/Yellow and the colors for Output 1 and 2 are Blue and Brown.

## **Preparations**

- a) Switch OFF all power.
- b) Disassemble the side and top panels by removing the screws from both sides of the Controller.
- c) Connect the sensor wires to the 12V Sensor terminal.
  - See 12V Sensor Terminal for details.
  - Commonly used colour code of wires are 0V=Blue, 12V=Brown and SIG=Black.
- d) Connect cable of feeder to controller. See Input/Output Terminal for details.
  - Connect to output cable of the controller to the feeder input cable. Be particularly aware of live, neutral and earth connection respectively.
- e) Connect power cable to controller.
  - See Input/Output Terminal for details.
  - Terminal AC power supply according to the selected AC voltage (230Vac or 115Vac) to get ready.
- f) Connect fuse in the fuse holder. Insert the fuse properly in the fuse holder in which both sides of the fuse are in contact with the fuse holder.
- g) Insert the fiber optic cable to the fiber-optic photoelectric sensor.
- h) Check input and output cables for grounding with multimeter to ensure safety.
- i) Check and tighten all incoming and outgoing cables termination.
- j) Screw all the panels back to the Controller. As a precaution, remember to tighten all screws.

## Operation

### 1) Power Up

FREQ  
00050.0



Ensure the 3 pin plug is fully in the socket and switch on the power.

Toggle the On/Off Switch on the Controller to on.

The first screen in the display will be the Frequency Setting screen.

### 2) Frequency Setting

FREQ  
00050.0

**Increase Button:** Increase the frequency value.  
**Decrease Button:** Decrease the frequency value.  
**Mode Button:** Switch to On/Off Output screen.  
**SET Button:** Save the current settings.

At the Frequency Setting screen, press the Increase/Decrease Button to adjust the frequency to the desired value. This value can be seen in the display. A maximum value of 510.2 Hz can be achieved.

These settings will remain in effect until the power is switched off. The frequency value will revert back to the original value when the Controller is powered up again.

To ensure the new value remains in effect when the power is switched on, adjust to the desired frequency and press the Set Button. The screen will flash the message “ROM UPDAT” which means the current settings are successfully saved into the memory.

### 3) On/Off Output

**+ON-OFF+**  
00050.0

**Increase Button:** Switch on the output.  
**Decrease Button:** Switch off the output.  
**Mode Button:** Return back to the frequency screen when output is switch on.  
Switch to the delay on time screen when the output is switch off.

**+ON-OFF-**  
00050.0

From the Frequency Setting Screen, press the Mode Button to access the On/Off Output screen and then press the Increase/Decrease to switch on/off the output.

### 4) Modifying Delay On Time

**ON TIME**  
0000010

**Increase Button:** Increase the delay off timing.  
**Decrease Button:** Decrease the delay off timing.  
**Mode Button:** Return to the Frequency Setting screen  
**SET Button:** Save the current setting

In order to change the delay timing, the output needs to be disabled. Navigate to the On/Off Output screen to disable the output

Once the output has been deactivated, press the Mode Button again to access the delay on timing setting. Then press Increase/Decrease Button to adjust to the desired delay on timing.

To save the settings into the memory, press the Set Button.  
Pressing the Mode Button at the Delay On Time Setting screen will enable the user to access the Delay Off Time setting screen

## 5) Modifying Delay Off Time



**Increase Button:** Increase the delay off timing.  
**Decrease Button:** Decrease the delay off timing.  
**Mode Button:** Return to the Frequency Setting screen  
**SET Button:** Save the current setting

In order to change the delay timing, the output needs to be disabled. Navigate to the On/Off Output screen to disable the output

In the Delay Off Timing screen, press the Increase/Decrease Button to adjust to the desired delay off timing.

To save the settings into the memory, press the Set Button.

To return to the Frequency Setting screen, press the Mode Button.