

GT-Series Turbine Vibrator

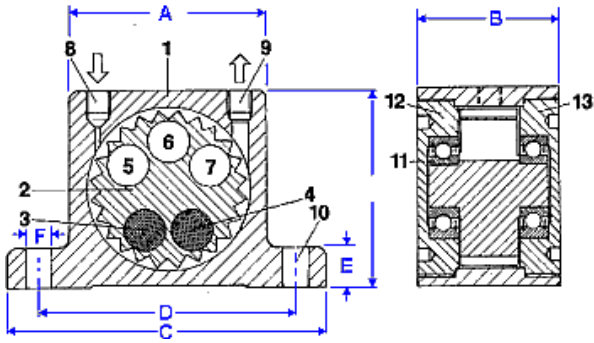

- Top-of-the-line pneumatic vibrators
- Extremely quiet
- Suitable for food and pharmaceutical industries
- No lubrication required

Dimensions:

Model	A		B		C		D		E		F		G/H BSP Thread	Weight	
	mm	inches	mm	inches	mm	inches	mm	inches	mm	inches	mm	inches		kg	Lbs
GT-8 GT-10 GT-10-S	50	1.97	33	1.30	86	3.38	68	2.68	12	0.47	7	0.27	1/8"	0.250 0.255 0.263	0.55 0.56 0.58
GT13 GT-16 GT-16-S	65	2.56	42	1.65	113	4.45	90	3.54	16	0.63	9	0.35	1/4"	0.565 0.580 0.614	1.24 1.28 1.35
GT20 GT-25 GT-25-S	80	3.15	56	2.20	128	5.04	104	4.09	16	0.63	9	0.35	1/4"	1.090 1.120 1.200	2.40 2.46 2.64
GT30 GT-36 GT-36-S	100	3.94	73	2.87	160	6.30	130	5.12	20	0.79	11	0.43	3/8"	2.200 2.300 2.530	4.85 5.10 5.57
GT40 GT-48 GT-48-S	120	4.72	83	3.26	194	7.64	152	5.99	24	0.94	17	0.67	3/8"	3.690 3.890 4.290	8.13 8.57 9.45

Performance:

Model	Frequency V.P.M. x 1000			Centrifugal force*						Air consumption / Minute					
	2 Bar 29 PSI	4 Bar 58 PSI	6 Bar 87 PSI	2 Bar N	29 PSI LBS	4 Bar N	58 PSI LBS	6 Bar N	87 PSI LBS	2 Bar Ltr.	29 PSI CF	4 Bar Ltr.	58 PSI CF	6 Bar Ltr.	87 PSI CF
GT-8 GT-10 GT-10-S	36.0 27.5 17.0	42.0 35.0 23.0	46.0 37.5 25.0	990 840 650	223 189 146	2060 1390 1350	464 313 304	2910 2400 1950	655 540 439	46	1.6	80	2.8	112	3.9
GT13 GT-16 GT-16-S	26.0 17.0 11.5	30.0 21.5 15.5	33.0 24.0 17.0	1400 1220 1100	315 275 248	2440 2090 1900	549 470 428	3730 3160 2700	839 711 608	120	4.2	200	7.0	290	10.2
GT20 GT-25 GT-25-S	17.0 12.0 8.5	20.0 15.5 11.0	23.0 17.0 13.0	2170 2120 2250	488 477 506	4040 3510 3600	909 790 810	5520 5070 4900	1242 1140 1102	185	6.5	325	11.4	455	15.9
GT30 GT-36 GT-36-S	13.0 8.0 6.1	14.0 10.0 7.2	16.0 13.0 8.3	3380 3290 4100	760 740 922	5430 5360 6200	1222 1206 1395	7540 7190 7500	1696 1618 1688	330	11.5	530	18.5	745	26.0
GT40 GT-48 GT-48-S	7.7 6.0 1.8	8.8 7.5 5.6	9.5 9.7 6.3	4300 4900 0	968 1102 0	7300 7700 7500	1642 1732 1688	9800 10500 12000	2205 2363 2700	425	15.0	700	24.6	970	34.2