

GTRF- Vibrator GTRF-Series Turbine Vibrator

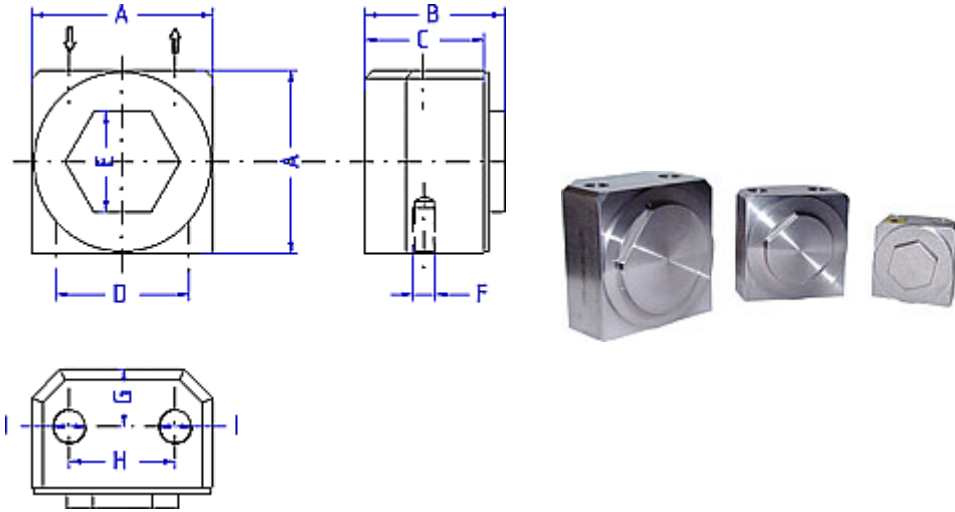

- Designed for food and pharmaceutical applications.
- Stainless steel construction
- Meets FDA requirements.
- No lubrication required.
- Extremely quiet.

Dimensions:

Model	A		B		C		D		E		F		I		Weight	
	mm	inches	mm	inches	mm	inches	mm	inches	mm	inches	mm	inches	Thread	kg	Lbs	
GT-10-RF	49	1.93	38	1.50	32	1.26	36	1.42	27	1.06	M 6	0.24	G 1/8"	0.525	0.24	
GT-16-RF	64	2.52	45	1.77	39	1.54	48	1.89	36	1.42	M 8	0.31	G 1/4"	1.002	0.45	
GT-25-RF	78	3.07	55	2.16	49	1.93	60	2.36	50	1.97	M 10	0.39	G 1/4"	1.807	0.82	

Performance:.

Model	Frequency V.P.M. x 1000			Centrifugal force*						Air consumption / Minute					
	2 Bar 29 PSI	4 Bar 58 PSI	6 Bar 87 PSI	2 Bar N	29 PSI LBS	4 Bar N	58 PSI LBS	6 Bar N	87 PSI LBS	2 Bar Ltr.	29 PSI CF	4 Bar Ltr.	58 PSI CF	6 Bar Ltr.	87 PSI CF
GT-10-RF	27.0	32.0	37.0	750	169	1350	304	2100	473	46	1.6	80	2.8	112	3.9
GT-16-RF	20.0	23.0	27.5	1700	383	2500	563	3700	833	120	4.2	200	7.0	290	10.2
GT-25-RF	14.0	17.0	19.5	2500	563	4150	935	5700	1,284	185	6.5	325	11.4	455	15.9